

## [1] Introduction

Superluminescent diodes (SLD) (or called Superluminescent light emitting diodes (SLED)) are optoelectronic semiconductor devices that emit broadband optical radiation based on superluminescence. In terms of construction, they are similar to laser diodes, containing an electrically driven p–n junction and an optical waveguide, but SLDs intentionally lack optical feedback, so that no laser action can occur. Optical feedback, which could lead to the formation of resonator modes and thus to pronounced structures in the optical spectrum and/or to spectral narrowing, is suppressed by means of tilting the facets relative to the waveguide, and can be suppressed further with anti-reflection coatings. Essentially, an SLD is a semiconductor optical amplifier with no input signal, where weak spontaneous emission into the waveguide mode is followed by strong laser amplification (therefore, this is called “amplified spontaneous emission (ASE)”).

SLDs are applied in situations where a smooth and broadband optical spectrum (i.e. low temporal coherence), combined with high spatial coherence and relatively high intensity, is required.

This paper summarizes the applications of SLDs.

## [2] Applications of SLDs

SLDs have been used for many different applications. The major application fields are

- (1) Optical Coherence Tomography
- (2) White light interferometry
- (3) Fiber-optic link testing
- (4) WDM PON systems
- (5) Fiber-optic sensors
- (6) Fiber-optic gyroscopes

The actual applications in each field are summarized in **Table 1**. More details are described in the following sections.

**Table 1** Applications of SLDs

Fields	Applications	Wavelengths
Optical Coherence Tomography (OCT)	<ul style="list-style-type: none"> <li>• Cornea and retina diagnostics</li> <li>• Cardiovascular imaging</li> <li>• Biomedical purposes or biology research</li> </ul>	800 nm band 1050 nm band 1310 nm band
White light interferometry	<ul style="list-style-type: none"> <li>• Measuring the chromatic dispersion of optical components</li> <li>• Measuring the distances (surface profile) by using Michelson interferometer with a CCD camera as detector</li> <li>• Detecting the reflections within a photonic integrated circuit</li> </ul>	800 nm band 1310 nm band 1550 nm band
Fiber-optic link testing	<ul style="list-style-type: none"> <li>• Measuring the chromatic dispersion or polarization mode dispersion of fiber-optic links</li> </ul>	1310 nm band 1550 nm band
WDM PON systems	<ul style="list-style-type: none"> <li>• Broad-band seed light source</li> </ul>	1550 nm band
Fiber-optic sensors	<ul style="list-style-type: none"> <li>• Measuring the temperature, strain or pressure in buildings, oil pipelines or oil fields (structural health; premises securitization)</li> </ul>	1550 nm band
Fiber-optic gyroscopes	<ul style="list-style-type: none"> <li>• Avionics navigation</li> </ul>	800 nm band 1550 nm band

## 2.1 Optical Coherence Tomography (OCT) Applications

Optical coherence tomography (OCT) is an optical signal acquisition and processing method using an interferometric technique to capture micrometer-resolution, three-dimensional images from within optical scattering media such as biological tissue. SLEDs have been used as a broad-band spectrum light source. Very wide-spectrum emitting over a  $\sim 100$  nm wavelength range have achieved sub-micrometer resolution. Optical coherence tomography is typically employing near infrared light. The use of relatively long wavelength light allows it to penetrate into the scattering medium.

Commercially available optical coherence tomography systems are employed in diverse applications, including art conservation and diagnostic medicine, notably in **ophthalmology** where it can be used to obtain detailed images from within the retina. Recently it has also begun to be used in **interventional cardiology** to help diagnose coronary artery disease.

There are two types of OCT: (1) **Time-domain OCT**, and (2) **Frequency-domain OCT**.

### (a) Time-domain OCT

Basic configuration of time-domain OCT system is shown in **Fig. 1** [1]. Light in an OCT system is broken into two arms—a sample arm (containing the item of interest) and a reference arm (usually a mirror). The combination of reflected light from the sample arm and reference light from the reference arm gives rise to an interference pattern, but only if light from both arms have travelled the "same" optical distance ("same" meaning a difference of less than a coherence length). By scanning the mirror in the reference arm, a reflectivity profile of the sample can be obtained.

The axial and lateral resolutions of OCT are decoupled from one another; the former being an equivalent to the coherence length of the light source and the latter being a function of the optics. The coherence length of a source and hence the axial resolution of OCT is defined as,

$$l_c = \frac{2 \ln 2}{\pi} \frac{\lambda_0^2}{\Delta \lambda} \approx 0.44 \cdot \frac{\lambda_0^2}{\Delta \lambda} \quad (1)$$

where  $\Delta \lambda$  is the 3dB bandwidth of the SLD spectrum, and  $\lambda_0$  is the central wavelength.

### (b) Frequency-domain OCT

In frequency domain OCT, the broadband interference is acquired with spectrally separated detectors, either by encoding the optical frequency in time with a spectrally scanning source or with a dispersive detector, like a grating and a linear detector array. One example of the frequency-domain OCT configuration with using a spectrally scanning source, is shown in **Fig. 2** [2]. Due to the Fourier relation (Wiener-Khinchine theorem between the auto correlation and the spectral power density), the depth scan can be immediately calculated by a Fourier-transform from the acquired spectra, without movement of the reference arm. This feature improves imaging speed dramatically, while the reduced losses during a single scan improve the signal to noise proportional to the number of detection elements. The parallel detection at multiple wavelength ranges limits the scanning range, while the full spectral bandwidth sets the axial resolution.

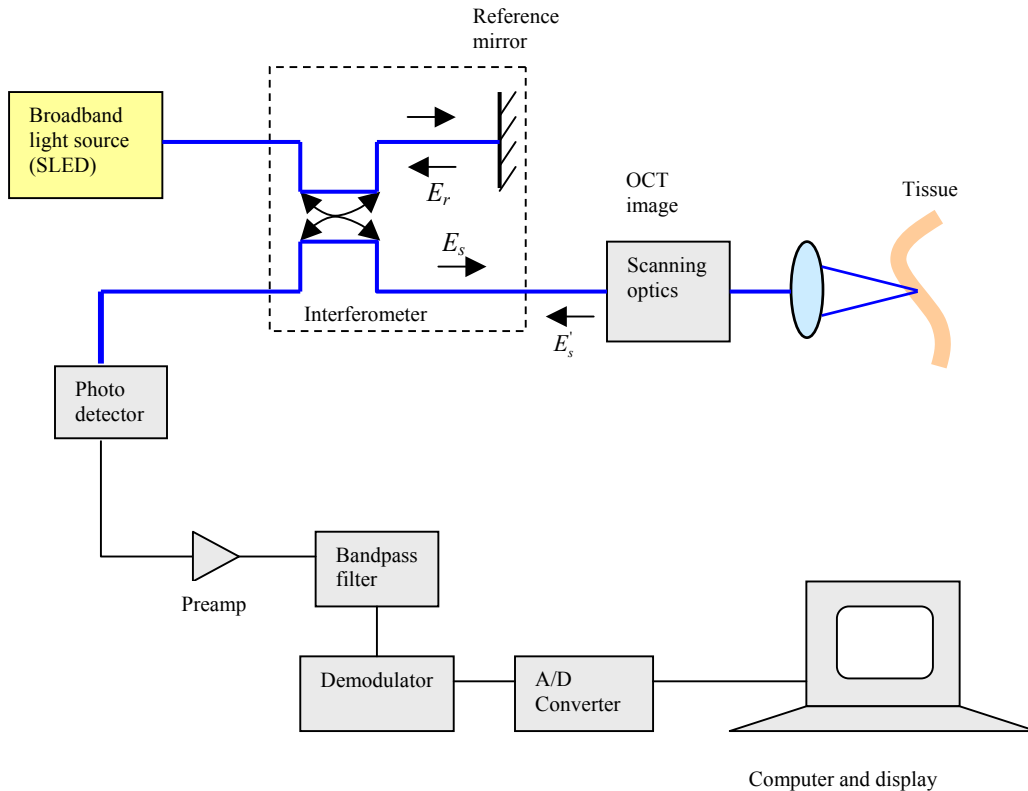

**Fig. 1** Basic configuration of time-domain OCT [1]

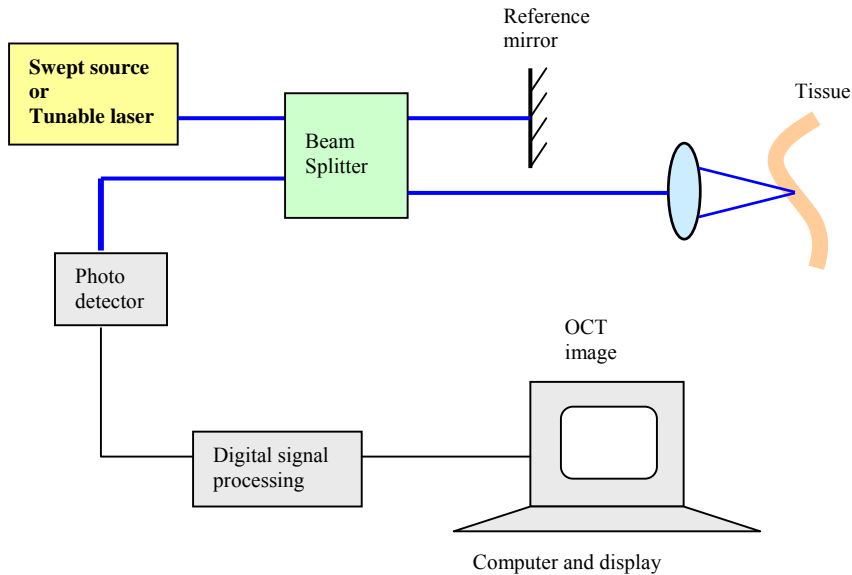

**Fig. 2** Basic configuration of frequency-domain OCT using Swept source or tunable laser [2]

## 2.2 White Light Interferometry

White light interferometry is to capture intensity data at a series of positions along the vertical axis where the surface is located by using the shape of the white-light interferogram, the localized phase of the interferogram, or a combination of both shape and phase.

An example of showing the operation principle is illustrated in **Fig. 3**. The light of a broadband light source (SLD) with short coherence length is split into two beams: an object beam and a reference beam. The object beam reflects from the object (sample), and the reference beam reflects off of a reference mirror. The two reflected beams are captured and recombined at the beam splitter. The superimposed beams are imaged by a CCD camera for processing. If the optical path for an object point in the measurement arm is the same as the optical path in the reference arm, there is constructive interference, which results in a high intensity in the camera pixel of the respective object point, for all wavelengths in the spectrum of the SLD. For object points having a different optical path, the interference is destructive, which results in a much lower intensity. In this way, the topographical structure of the sample is converted to light intensity difference, and, therefore, to the CCD output signals, which are compiled and analyzed.

One example of white light interferometry application is to measure the surface roughness on semiconductor wafers [3].

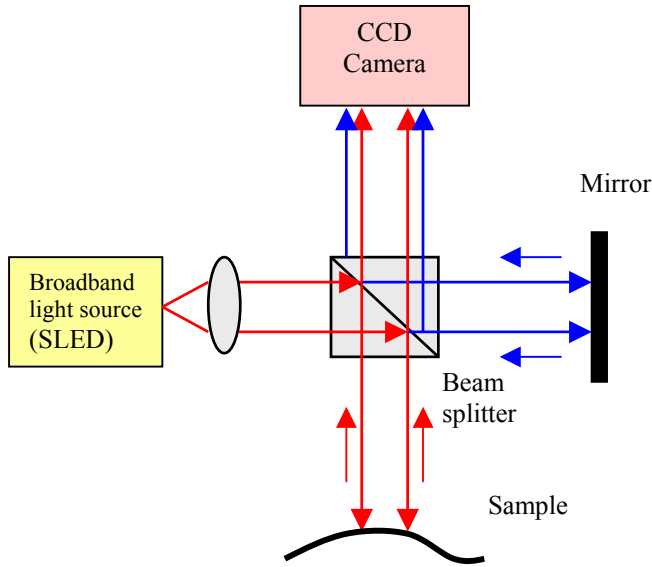

**Fig. 3** White light interferometry basic configuration.

### 2.3 Fiber-Optic Link Testing

SLDs are used in the diagnostics of optical fiber communication networks in the 1310 nm and 1550 nm bands. The **chromatic dispersion** of an optical medium is the phenomenon that the **phase velocity and group velocity** of light propagating in a transparent medium depend on the optical frequency. Dispersion has an important impact on the propagation of optical pulses, because a pulse always has a finite spectral width (bandwidth), so that dispersion can cause its frequency components to propagate with different velocities. Normal dispersion, for example, leads to a lower group velocity of higher-frequency components, and thus to a positive chirp, whereas anomalous dispersion creates negative chirps. The frequency dependence of the group velocity also has an effect on the pulse duration. If the pulse is initially unchirped, dispersion in a medium will always increase its duration (dispersive pulse broadening).

In optical fibers, there is usually some slight difference in the propagation characteristics of light waves with different polarization states. This is called **polarization mode dispersion (PMD)**[3]. A **differential group delay** can occur even for fibers that according to the design should have a rotational symmetry and thus exhibit no birefringence. This effect can result from random imperfections or bending of the fibers, or from other kinds of mechanical stress, and is also affected by temperature changes. Mainly due to the influence of bending, the PMD of a cabled fiber can be completely different from that of the same fiber on a spool. Modern fiber cables as used in fiber-optic links have been optimized for low PMD, but the handling of such cables can still have some influence. PMD can have adverse effects on optical data transmission in fiber-optic links over long distances at very high data rates, because portions of the transmitted signals in different polarization modes will arrive at slightly different times. Effectively, this can

cause some level of pulse broadening, leading to inter-symbol interference, and thus a degradation of the received signal, leading to an increased bit error rate.

The **chromatic dispersion** and **polarization mode dispersion (PMD)** can be measured by using the large bandwidth, high power spectral density, and low ripple characteristics of SLDs.

## 2.4 WDM PON Systems

The Wavelength Division Multiplexing (WDM) Passive Optical Networks (PON) has been used and developed as one of the approaches for Fiber To The Home (FTTH) network systems [5][6]. As a low-cost laser source at the Optical Network Unit (ONU) in such WDM PON systems, the Fabry Perot (FP) laser diode (LD) wavelength is locked to a selected wavelength channel of the broad-band Amplified Spontaneous Emission (ASE) source.[6]. **Fig. 4** shows an architecture for upstream transmission employing wavelength-locked FP LDs [6]. A broad-band ASE source (such as SLD) with an optical circulator is located at the central office. The broad-band ASE is transmitted to the remote node where an Arrayed Waveguide Grating (AWG) slices the ASE spectrally. The spectrally sliced ASE is injected into the FP LD located at the ONU.

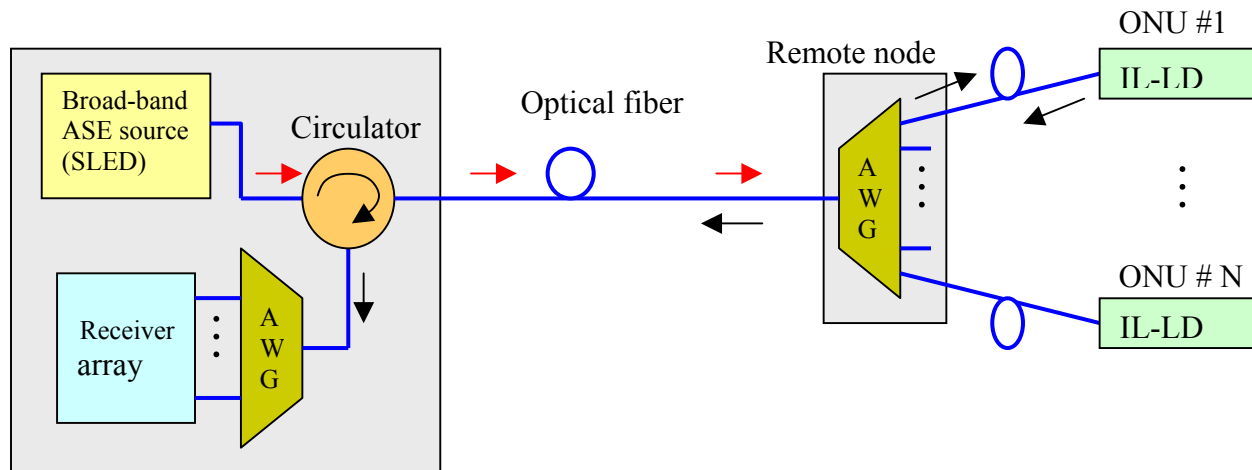

**Fig. 4** WDM PON System Upstream Configuration

## 2.5 Fiber-Optic Sensors (FOS)

### (a) Advantages of FOS

- Small size
- No electrical power is needed at the remote location,
- Many sensors can be multiplexed along the length of a fiber by using different wavelengths of light for each sensor, by sensing the time delay as light passes along the fiber through each sensor.

### (b) Types of FOS

There are two types of fiber optic sensors:

- Intrinsic sensors: **Optical fiber itself** is used as the sensing element.
- Extrinsic sensors: Optical fiber is used as a **means of relaying signals from a remote sensor** to the electronics that process the signals.

### (c) Intrinsic Sensors

- **Fiber-Optic Strain, Temperature, and Pressure sensors**

The optical characteristics of an optical fiber is sensitive to the strain, temperature, and pressure, which modulates the intensity, phase, polarization, wavelength, or transit time of light in the fiber. A particularly useful feature of intrinsic fiber optic sensors is that they can, if required, provide **distributed sensing over very large distances**.

Optical fiber sensors for temperature and pressure have been developed for **downhole measurement in oil wells**. The fiber optic sensor is best suited for this environment as it functions at temperatures too high for semiconductor sensors (distributed temperature sensing).

Fiber-optic sensors have been developed to measure co-located temperature and strain simultaneously with very high accuracy using **fiber Bragg gratings**. This is particularly useful when acquiring information from small complex structures. Brillouin scattering effects can be used to detect strain and temperature over larger distances (20–30 kilometers). The fiber sensor is especially useful for harsh environment.

#### **Example: Bragg grating sensors for strain and temperature**

A schematic diagram of the fiber Bragg grating sensor is shown in **Fig. 5**.

The Bragg wavelength can be expressed as,

$$\lambda_B = 2n\Lambda \quad (2)$$

where  $n$  is the mode index of the fiber, and  $\Lambda$  is the grating period. Equation (1) gives,

$$\Delta\lambda_B = 2\Lambda \cdot \Delta n + 2n \cdot \Delta\Lambda \quad (3)$$

where  $\Delta\lambda_B$ ,  $\Delta n$  and  $\Delta\Lambda$  express a small change of  $\lambda_B$ ,  $n$ , and  $\Lambda$ , respectively.

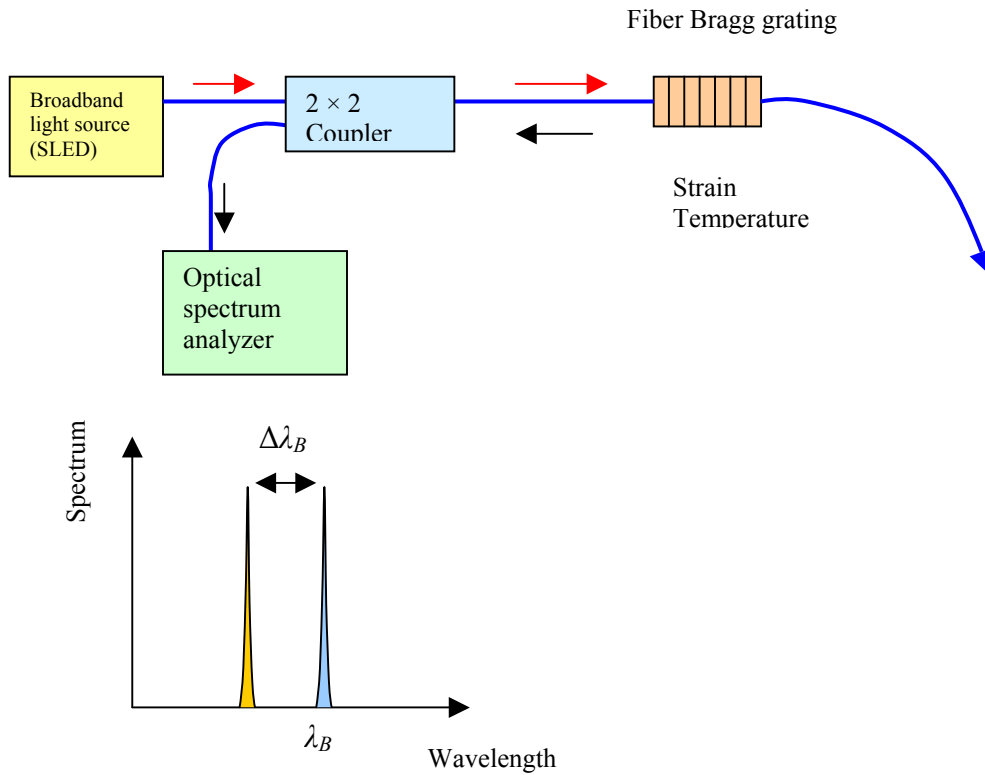

**Fig. 5** Fiber Bragg grating sensor configuration for temperature and strain measurement

- **Fiber-Optic Voltage Sensors**

A fiber-optic AC/DC voltage sensor in the middle and high voltage range (100–2000 V) can be created by inducing measurable amounts of Kerr nonlinearity in single mode optical fiber by exposing a calculated length of fiber to the external electric field. The measurement technique is based on polarimetric detection and high accuracy is achieved in a hostile industrial environment.

- **Fiber-Optic High Frequency Electromagnetic Field Sensors**

High frequency (5 MHz–1 GHz) electromagnetic fields can be detected by induced nonlinear effects in fiber with a suitable structure. The fiber used is designed such that the Faraday and Kerr effects cause considerable phase change in the presence of the external field. With appropriate sensor design, this type of fiber can be used to measure different electrical and magnetic quantities and different internal parameters of fiber material.

- **Fiber-Optic Electrical Power Sensors**

Electrical power can be measured in a fiber by using a structured bulk fiber ampere sensor coupled with proper signal processing in a polarimetric detection scheme. Experiments have been carried out in support of the technique.

- **Fiber-Optic Hydrophone Sensors** for seismic and sonar applications.

Hydrophone systems with more than one hundred sensors per fiber cable have been developed. Hydrophone sensor systems are used by the oil industry as well as a few countries' navies. Both bottom-mounted hydrophone arrays and towed streamer systems are in use.

- **Fiber-Optic Microphone and Fiber Optic Based Headphone**

Fiber optic microphone and fiber-optic based headphone find application in areas with strong electrical or magnetic fields, such as communication amongst the team of people working on a patient inside a magnetic resonance imaging (MRI) machine during MRI-guided surgery.

#### (d) Extrinsic Sensors

Extrinsic fiber optic sensors use an optical fiber cable, normally a multimode one, to transmit modulated light from either a non-fiber optical sensor, or an electronic sensor connected to an optical transmitter. A major benefit of extrinsic sensors is their ability to reach places which are otherwise inaccessible. Extrinsic fiber optic sensors provide excellent protection of measurement signals against noise corruption:

- Measurement of temperature inside aircraft jet engines by using a fiber to transmit radiation into a radiation pyrometer located outside the engine.
- Measurement of the internal temperature of electrical transformers, where the extreme electromagnetic fields present make other measurement techniques impossible.
- Measurement of vibration, rotation, displacement, velocity, acceleration, torque, and twisting.
- Hydrogen sensors

## 2.6 Fiber-Optic Gyroscopes

The interferometric fiber optic gyroscope (IFOG) uses an optical interferometer for the very high-resolution readout of the Sagnac phase shift induced between two counter-propagating waves in an optical closed path when the plane of propagation undergoes angular rotation. The basic scheme is illustrated in **Fig. 6**. It is a passive interferometer where the fiber optic coupler is employed to split the radiation from the light source into two counter-propagating waves, clockwise (CW) and counterclockwise (CCW), in the fiber coil and to recombine the waves, after propagation, on a photodetector PD. The phase difference is thus cumulated over a long fiber coil for obtaining high responsivity with a compact device. For ideal fibers and components, the output photo-generated current  $I$  has the following expression:

$$I = I_0(1 - \cos \varphi_S) \quad (4)$$

where  $\varphi_S$  is the so called Sagnac phase shift, and

$$I_0 = \sigma \frac{P}{2} \quad (5)$$

where  $\sigma$  is the photodetector responsivity and  $P$  is the power coupled into the input fiber. The Sagnac phase shift  $\varphi_S$  is given by (see Fig.7),

$$\varphi_S = \frac{8\pi AN\Omega_p}{\lambda c} \quad (6)$$

$$\Omega_p = \bar{\Omega} \cos \psi \quad (7)$$

where

$A$ : Area enclosed by each fiber loop.

$N$ : Number of loops of the fiber coil

$\bar{\Omega}$ : Rotating angular velocity

$\Psi$ : Angle with respect to the perpendicular to the plane.

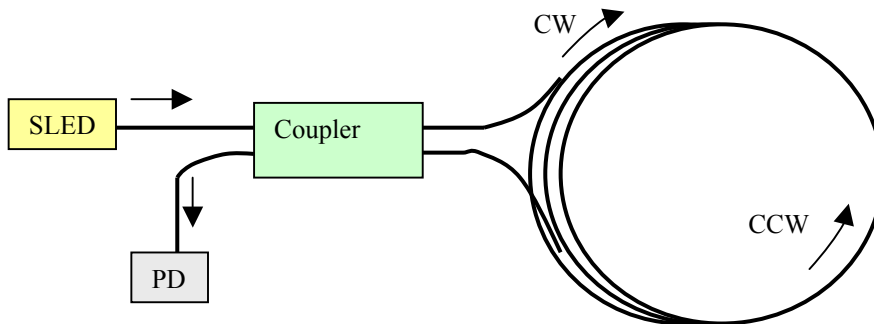

**Fig. 6** Basic scheme of the fiber optic gyroscope (FOG)

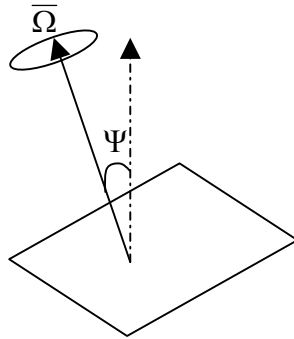

**Fig. 7** Rotating angle

## References

- [1] J. M. Schmitt, "Optical coherence tomography (OCT): a review", IEEE Selected Topics in Quantum Electron., vol. 5, pp. 1205-1215, July/Aug. 1999.
- [2] [http://en.wikipedia.org/wiki/Optical\\_coherence\\_tomography](http://en.wikipedia.org/wiki/Optical_coherence_tomography)
- [3] R. T. Blunt, "White light interferometry – a production worthy technique for measuring surface roughness on semiconductor wafers".  
<http://www.csmantech.org/Digests/2006/2006%20Digests/4B.pdf>
- [4] [http://www.rp-photonics.com/polarization\\_mode\\_dispersion.html](http://www.rp-photonics.com/polarization_mode_dispersion.html)
- [5] S. -J. Park, C. -H. Lee, K.-T. Jeong, H.-J. Park, J.-G. Ahn, and K.-H. Song, "Fiber-to-the home services based on wavelength-division-multiplexing passive optical network", J. Lightwave Technol., vol. 22, pp. 2582-2591, Nov. 2004.
- [6] H. D. Kim, S.- G. Kang, and C.-H. Lee, "A low-cost WDM source with an ASE injected Fabry-Perot semiconductor laser", IEEE Photon. Technol. Lett., vol. 12, pp. 1067-1069, Aug. 2000.
- [7] *Handbook of Fibre Optic Sensing Technology*, edited by José Miguel López-Higuera, 2000 John Wiley & Sons Ltd.